

Picosecond Laser Photophysics. Group 3A Phthalocyanines

James H. Brannon and Douglas Magde*

Contribution from the Department of Chemistry, University of California, San Diego, California 92093. Received May 14, 1979

Abstract: The primary electronic photophysical processes were characterized for ambient-temperature solutions of chloroaluminum, chlorogallium, and chloroindium phthalocyanines in the solvent 1-chloronaphthalene. Using a wide range of recently introduced laser procedures, we measured the fluorescence yields ($\phi_f = 0.58, 0.31, \text{ and } 0.031$, respectively), the fluorescence lifetimes ($\tau_f = 6.8, 3.8, \text{ and } 0.37$ ns), and the triplet yields ($\phi_T = 0.4, 0.7, \text{ and } 0.9$). From the data, we may also infer that the radiative lifetime (τ_0) is similar for all species and that the internal conversion yields (ϕ_{ic}) are too small to measure reliably. We compare our results with existing data for phthalocyanines and other metalloporphyrins and comment on their relation to theories of radiative and nonradiative decay.

Among the many molecular complexes containing a central metal surrounded by a macrocyclic ligand system, the metallophthalocyanines constitute the oldest and perhaps the most important strictly synthetic example. Thousands of tons are produced annually, primarily for use as pigments. Their thermal and photostability are essential here and in other proposed applications ranging from lubricants to semiconductors. They have been used as the active media for dye lasers and still remain the best passive Q-switch for ruby lasers. Their close resemblance to the naturally occurring porphyrins offers additional warrant for the detailed investigation of their photophysical properties.

We report here a study of three group 3A phthalocyanines. We measured the fluorescence quantum yield ϕ_f , the singlet to triplet intercombination conversion efficiency ϕ_T , and the fluorescence lifetime (that is, the lowest singlet state lifetime) τ_f for chloroaluminum (CAP), chlorogallium (GAP), and chloroindium (CIP) phthalocyanine. All data refer to room temperature solutions in 1-chloronaphthalene. From these data we could infer the rates for direct S_1 to S_0 internal conversion. We expected to find measurable internal conversion and were curious whether the presence of the central metal would induce a heavy-atom effect upon this process, as it so clearly does for singlet-triplet intercombination processes. Although we knew of no special reason to expect one, a possible heavy-atom effect on internal conversion had been documented for certain metalloporphyrins.^{1,2}

Our results, however, show nothing so novel: the radiative rate is nearly identical for the three molecules, an ordinary heavy-atom effect³ on the intersystem crossing rate exists, and little or no internal conversion occurs. Only in CIP do we obtain a nonzero value for internal conversion, and it does not exceed the uncertainty of measurement.

Experimental Section

Chemicals. Chloroaluminum and chlorogallium phthalocyanine were obtained as commercial products from Eastman Kodak Co. Chloroindium phthalocyanine was synthesized according to a slightly modified procedure of Colaitis.⁴ Indium monochloride (Alfa) was combined in a 1:4 mole ratio with *o*-cyanobenzamide (Pfaltz and Bauer, Inc.) in an N_2 atmosphere. The solid mixture, which melted at about 180 °C, turned dark blue upon heating at 250 °C in an oil bath. After 45 min the solution was cooled to give a tarry substance, deep purple in color. Extraction with approximately 3 L of hot acetone yielded purple crystals, which were identified as chloroindium phthalocyanine by the appearance of the characteristic phthalocyanine absorption spectrum in 1-chloronaphthalene and the very high melting point (>350 °C). All phthalocyanines were purified by vacuum sublimation.

Solubility is a problem for phthalocyanines. This was even more true for the purified compounds than for the finely ground commercial preparations. Constant stirring over low heat for a period of days was required in order to solubilize the crystals and achieve maximum molar

absorptivity. The solvent was 1-chloronaphthalene (Eastman Kodak Co., used without further purification). In this solvent the maximum of the phthalocyanine absorption spectra ($\epsilon_{\text{max}} \approx 2.5 \times 10^5 \text{ L mol}^{-1} \text{ cm}^{-1}$) occurs at the fundamental wavelength of the ruby laser, 694.3 nm. Other workers studying phthalocyanines have often used this solvent.

Triplet Yield. The triplet quantum yield was measured by observing the partial recovery of ground-state bleaching in a picosecond "pump and probe" experiment. The procedure was detailed by Lessing and co-workers,⁵ but had been used earlier by others, in particular by Magde and co-workers² in a study of a series of porphyrins which led directly to the present investigations.

The experimental configuration is shown in Figure 1. A single picopulse was extracted with a Pockels cell and polarizer from a train of picosecond pulses emitted by an Apollo Model 5 mode-locked ruby laser. The pulse was amplified and then passed through a beam splitter which transmits 70% of the incident energy and reflects the remaining 30%. The transmitted pump pulse, after mild focusing, was incident upon the sample cell with an energy of 0.1 mJ and a temporal duration of 35 ps. The duration was measured using noncollinear type I second harmonic generation. The reflected probe pulse was directed around a variable delay path so that it could be made to arrive at the sample cell at times preceding the pump or to be delayed by up to 12 ns. After the delay line, the probe passed through a polarizer oriented at 54.7° to the plane of polarization of the pump. This allows one to measure the "true" level kinetics of the excited state, without any contribution to the observed signal due to rotational diffusion of unexcited molecules. The probe was attenuated by two orders of magnitude before being brought to a focus at the sample cell, where it had a somewhat smaller area than the pump. Photodetectors (RCA 30808 silicon p-i-n photodiodes) placed before and after the sample monitored the incident and transmitted intensities for both pump and probe beams. The output of the detectors was fed into a Camac-based charge digitizer (EGG Model QD 410) with subsequent numerical printout. In order to account for random shot to shot variation in the intensity of the exciting pump pulse, all laser shots were normalized to constant photons absorbed. This number was obtained by the use of photodetectors to monitor incident and transmitted intensity of the pump pulse, the difference between which was assumed to be "lost" to sample absorption.

The more energetic pulse, the pump, created an excited-state population. The probe pulse measured ground-state absorption at times preceding or following the arrival of the pump. The probe was too weak to cause ground-state bleaching itself. Since a certain fraction ϕ_T of molecules initially excited into the singlet state decay to long-lived triplets, rapid recovery of ground-state absorption is only partial. A plot of change in ground-state absorbance ΔA vs. delay time between pump and probe Δt will show an initial bleaching at $\Delta t = 0$ followed by a partial decay to a plateau in a time corresponding to the singlet lifetime. The absorbance change in the plateau region ΔA_p divided by that at delay time zero ΔA_0 gives the triplet quantum yield ϕ_T . The ultimate decay of the triplet is not observable with a 12-ns delay line.

This simple analysis assumes that the molar absorptivity from the excited singlet and triplet is negligible compared to the ground-state value of 2.5×10^5 at the wavelength we were using. Given the exceptionally large value of the latter, we expected that we could neglect

excited-state absorptions. For the related porphyrins, previous work² gives molar absorptivities below $5000 \text{ L mol}^{-1} \text{ cm}^{-1}$ in the red. Nevertheless, we attempted to observe transient absorption of picosecond continuum radiation generated in a CCl_4 liquid cell, following essentially the procedure used for the porphyrin studies.² Continuum generation required about 5 mJ of fundamental ruby radiation. A half-meter Spex Model 1870 spectrograph dispersed the continuum after the cell and Polaroid Type 57 sheet film was used for detection. No sign of transient absorption accompanied evident ground-state bleaching. The relatively sharp structure of phthalocyanine absorption makes it unlikely that prominent excited-state absorption would be entirely overlapped and obscured by the ground-state features. In an attempt to increase sensitivity by increasing concentration, we also studied CAP dissolved in ethanol. We still found no measurable transient absorption in the region of the red ground-state absorption.

Fluorescence Decay. Determination of fluorescence decay times of the three phthalocyanines was accomplished using the picosecond laser pulse as a δ -function excitation source with fluorescence monitored at 90° . The luminescence was collected with a fast achromat lens and brought to a focus on a Hewlett-Packard 4203 silicon photodiode. An identical detector was placed before the sample to monitor the excitation pulse. The outputs of both detectors were fed into the $50\text{-}\Omega$ load of a Tektronix 485 oscilloscope. The overall response time of the system was 1 ns. Both channels were displayed simultaneously for photographic recording. The deconvoluted data were analyzed by plotting relative intensity levels vs. time on semilog graph paper. The straight lines obtained gave the decay times τ_f .

For both the ground-state bleaching and the fluorescence decay experiments, 1-cm sample cells were used. For nearly saturated solutions, this corresponded to low-level absorbances of 0.93, 0.61, and 0.33 for CAP, GAP, and CIP, respectively.

Fluorescence Yield. The absolute fluorescent quantum yields of CAP and GAP were measured by the thermal blooming method. Application of this method to quantum-yield determination has recently been demonstrated in detail.^{6,7} A 2-mW He-Ne laser was used as the excitation source. The beam traversed a 20-cm lens before impinging on the sample cell. Because the refractive index decreases for a temperature increase in this solvent, the laser beam expands or "blooms" for a fraction of a second after a shutter is opened until a steady-state temperature distribution is approached. The decreasing intensity at beam center was monitored by a photodetector (Hewlett-Packard 4203 silicon photodiode) located in the "far field." The detector output was fed into a Model 805 Biomation waveform recorder for A/D conversion and storage. Thermal blooming decay curves were subsequently plotted on a Houston Omniscrite strip chart recorder for analysis.

As in all quantum-yield measurements by thermal blooming, a nonluminescent reference absorber must be used. In this case the compound tetracyanoaminoanthraquinone in 1-chloronaphthalene was employed. The absorbances of both reference and sample were closely matched, although this is not a crucial condition. Experimental determinations were performed for a variety of conditions, including varying the phthalocyanine concentration over an order of magnitude, employing cell lengths of 2, 5, and 10 mm, and changing the incident intensity of the laser with neutral density filters. Regardless of the conditions, our ϕ_f values remained the same within experimental uncertainty. For all experimental runs, the necessary solvent blank correction was made.

To obtain the ϕ_f value for CIP, fluorescence yield measurements were made relative to CAP using the procedure advocated by Demas and Crosby.⁸ As a check on the thermal blooming results, we also measured the yield of GAP relative to CAP. For excitation we used an H3 quartz-iodine lamp in conjunction with a Jobin-Yvon H-20 monochromator equipped with entrance and exit slits of 4-nm band-pass. The emission detection system was positioned at 90° from the direction of excitation. Emitted radiation was focused onto the entrance slit of another J-Y H-20 monochromator set for an 8-nm band-pass. This monochromator was interfaced to an RCA 31034 red-sensitive photomultiplier operating at 2000 V and cooled to -20°C . Wavelength was scanned automatically with a stepper motor. The output of the photomultiplier was plotted on a strip chart recorder for manual analysis.

Since the absorption maxima for all three phthalocyanines occurs at 694 nm, the excitation monochromator was adjusted for this wavelength. The exciting light was vertically polarized. The emitted

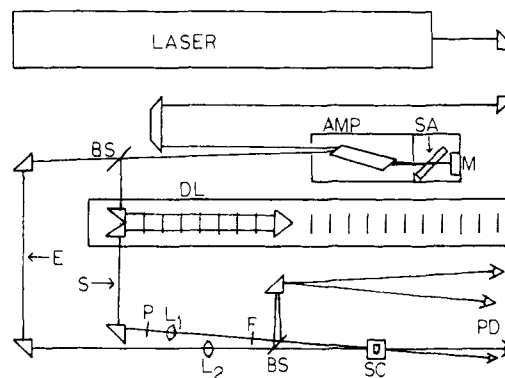

Figure 1. The experimental configuration employed in the determination of triplet quantum yields: AMP, ruby laser amplifier; SA, saturable absorber used to sharpen main pulse and remove satellites; M, mirror; BS, beam splitter; DL, optical delay line; E, exciting pump pulse; S, sampling probe pulse; P, polarizer; L₁, 500-mm optical lens; L₂, 1000-mm optical lens; F, neutral density filter; SC, sample cell; PD, photodetectors. Prisms are not labeled.

light was polarized at 54.7° to the vertical. This polarization combination eliminates the possibility of complicating effects due to rotational diffusion during the short lifetime of the indium species.⁹ The sample concentrations were all carefully adjusted by dilution to give an optical density of 0.33 in the 1-cm sample cell. Since the only difference in the emission characteristics of the phthalocyanines is intensity and not spectral distribution, it was not necessary to calibrate the emission monochromator and photomultiplier for wavelength-variable sensitivity for this relative measurement. The relative values of ϕ_f for GAP and CIP were calculated from the equation $Q_x = Q_r(A_x/A_r)$, where Q is the luminescent quantum yield and A is the integrated area from 620 to 800 nm under the emission curve. The subscripts x and r refer to the unknown and reference samples, respectively. The factors for absorbance and refractive index ratio have been deleted since both reference and unknown have equal absorbances in the same solvent.

Results

The experimental values for ϕ_T , τ_f , and ϕ_f are listed in Table I together with associated error estimates.

The results obtained for ϕ_T represent the mean of two separate experimental determinations, separated by several days. A typical decay curve derived from a ground-state bleaching experiment on CIP is displayed in Figure 2. Also displayed in the figure are the parameters used in the calculation of ϕ_T . The error estimate associated with the ϕ_T values reflects the normalization variation, as well as random error and inherent imprecision of the method and equipment. These limit the precision to no better than 10%.

The reported values of τ_f are the mean of six experimental determinations each for CAP and GAP. Because of CIP's very weak fluorescence and short lifetime, a determination of τ_f could not be made for that molecule.

The value of ϕ_f for CAP is an absolute determination using the thermal blooming method, independent of any previously measured "standard". We believe that for ϕ_f values in the range observed for CAP the method's accuracy is 10% or better.

In calculating the relative yields of CIP and GAP, as described previously, we used for Q_r our thermal blooming value of 0.58 for CAP. From the emission curves, the following area ratios were obtained: GAP/CAP = 0.48, CIP/CAP = 0.051. Q_x was then calculated for GAP and CIP, and the CIP value is displayed in Table I. There is a slight disagreement, on the order of 10%, between our ϕ_f value for GAP measured by thermal blooming and that measured relative to CAP. The value for GAP in the table represents a weighted mean of the thermal blooming value and the relative measurement, with

Table I. Photophysical Data for CAP, GAP, and CIP

compd	ϕ_T	τ_f , ns	ϕ_f	ϕ_{ic}	τ_0 , ns	$\tau_{0,S-B}$, ns
CAP	0.4 ± 0.08	6.8 ± 0.6	0.58 ± 0.04	0	11.7	9.5
GAP	0.7 ± 0.10	3.8 ± 0.3	0.31 ± 0.03	0	12.1	10.0
CIP	0.9 ± 0.12	$(0.37)^a$	0.031 ± 0.004	0.07	$(12)^b$	c

^a Value obtained from product of ϕ_f and the assumed value of τ_0 . ^b Assumed value. ^c Value not obtained owing to small fluorescence yield.

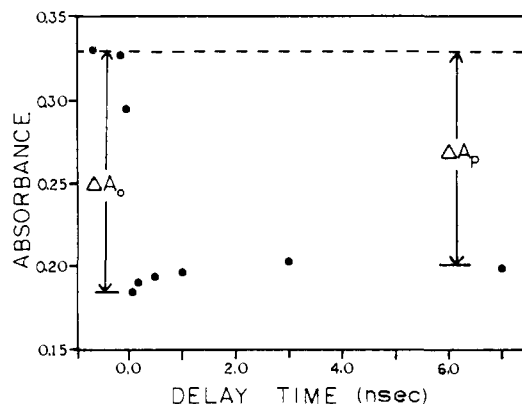

Figure 2. Decay curve derived from ground-state bleaching experiment on a 1.4×10^{-6} M solution of CIP in 1 cm of 1-chloronaphthalene. The absorbance for the sampling probe pulse remains near its low level value (dashed line), as measured on a Beckman Acta III spectrophotometer, for all negative delay times. As the delay time becomes slightly positive, the absorbance decreases abruptly to its minimum value. With increasing delay times, the absorbance increases until a plateau is reached, indicative of triplet-state buildup.

the thermal blooming yield being considered slightly more accurate. The displayed error limits are the result of estimated error propagation throughout the experiment.

The internal conversion yields are simply calculated for each compound from the equation $1 - \phi_f - \phi_T$.

Radiative lifetimes τ_0 are calculated as τ_f/ϕ_f . For CIP the process is reversed, because a good value of τ_f was not obtained. We assumed that CIP has a τ_0 similar to CAP and GAP and used ϕ_f to calculate τ_f . (This value is consistent with a value deduced from the picosecond bleaching experiment but is more precise and probably more accurate.)

As a check on these values, calculated lifetimes were obtained using the Strickler-Berg equation.¹⁰ These are denoted $\tau_{0,S-B}$ in the table. A degeneracy factor of $1/2$ was used based on previous work in this laboratory.¹¹ That the two values do not show total agreement is not unexpected. A difference of less than 20% is often considered good agreement.^{10,12} More important is the consistency between the values for CAP and GAP. This is expected considering the almost identical electronic makeup for the two species.

Discussion

Luminescence work on phthalocyanine molecules¹³⁻¹⁵ offers ample evidence that metal substitution does affect luminescence behavior.

Previous literature reports on phthalocyanine fluorescent quantum yields are not consistent with our values. Pine¹⁶ has listed a ϕ_f value of 10^{-4} for CAP in 1-chloronaphthalene, although a number of experimental conditions were not indicated. We, as well as others,^{15,17,18} are in agreement with Pine as to the magnitude of the fluorescence lifetime. His ϕ_f value, however, taken together with the agreed-upon fluorescence lifetime of 6 ns for CAP, produces an unreasonable value of 60 μ s for the radiative lifetime. Radiative lifetimes for such strongly absorbing molecules are expected to be on the order of nanoseconds.

A Russian group¹⁸ has reported luminescence work for a number of phthalocyanines in ambient-temperature solutions of quinoline, which should show luminescence yields similar to or somewhat larger than that of 1-chloronaphthalene. Again details of the quantum-yield measurements are missing. For GAP, they obtain a ϕ_f value of 0.077, significantly lower than our value of 0.31. Strangely, they obtain a higher value of 0.10 for the heavier bromogallium phthalocyanine. This last result is at odds with the expected heavy-atom effect.³ Nowhere could we find values to compare with our result for CIP.

It was because of such uncertainties, which are typical of conventional luminescence quantum yield measurements in the red, that we turned to new, absolute, calorimetric procedures. In contrast, our fluorescence lifetime values are in agreement with expected¹⁹ and experimental^{15,17,18} results for strongly absorbing dyes of the type considered here. These values, used in conjunction with our fluorescence yields, give experimental radiative lifetimes τ_0 which agree well with the Strickler-Berg estimates $\tau_{0,S-B}$.

There are numerous reports in the literature of singlet-triplet conversion efficiencies for other metalloporphyrin-type complexes. The invariable method of measurement is flash photolysis, which has been successful on time scales ranging from microseconds^{15,17} to picoseconds.² Our own results, like those earlier studies, show an increase in ϕ_T with the increasing atomic weight of the central metal due to the heavy-atom effect. There are no literature values of ϕ_T explicitly for CAP, GAP, or CIP, although related molecules which have been measured^{15,17,18} do exhibit triplet yields similar to our values. From our data for ϕ_T and τ_f , we may calculate the rate constants for intersystem crossing as $k_{isc} = \phi_T/\tau_f$. The values of 0.059, 0.18, and 2.4 ns^{-1} for CAP, GAP, and CIP, respectively, do increase in the expected order. A theoretical treatment for k_{isc} was given by Gouterman and others.²⁰

The role played by internal conversion in porphyrin-type molecules is controversial. The data in Table I indicate, at least for CAP and GAP, that the internal conversion process is negligible. For CIP, it is possible that a small amount of internal conversion may occur. But considering the uncertainty involved, it is entirely possible that ϕ_{ic} is zero for CIP also. Whether these findings are indicative of a general trend is at present not clear. Work due to Gurinovich and Jagarov¹⁷ indicates for a series of porphyrin complexes that internal conversion is present, albeit small. Although they make no explicit mention of ϕ_{ic} values, typical values of <8% can be obtained from their reported ϕ_f and ϕ_T data. No uncertainty limits were included, so it is hard to assess the validity of this conclusion. A much stronger argument can be made from Callis's work.¹ He found appreciable ϕ_{ic} yields for a selection of porphyrin complexes using a calorimetric approach. Values in the range 20-50% were reported. In contrast, Gradyushka and others¹⁵ have observed that the sum $\phi_f + \phi_T = 1$ is obeyed for a series of porphyrin complexes. They consistently maintain that the whole porphyrin series, "excluding perhaps nonfluorescent metalloporphyrins", obey this relation. Finally, a study by Magde and co-workers,² using picosecond methods very similar to those adopted here, found small but measurable ϕ_{ic} values. This last study, like most others, did not examine the systematic effect of changing the metal within one column of the periodic

table while keeping the rest of the molecule fixed. We studied the group 3A series of the phthalocyanines in order to have a clear test. We are forced to conclude that internal conversion yields for this series are small at best—sufficiently small, in fact, to obscure any “heavy-atom effect” which might exist.

Modern theories of nonradiative coupling, first developed by Robinson and Frosch^{21,22} and Byrne and co-workers,²³ and later extended,²⁴ indicate that the $S_1 \rightarrow S_0$ internal conversion is an inefficient process for rigid planar π systems like the aromatics and, perhaps, the porphyrins. Experiments show that this is often true,²⁵ but the range of applicability is not yet clear. According to the Robinson and Frosch model, molecules possessing a center of symmetry have small values for k_{ic} more because of a symmetry forbiddance than because of other factors.²³ Thus for the highly symmetric phthalocyanine systems considered here, we should expect to find small, if not negligible, values for ϕ_{ic} .

Our results also explain the outstanding performance of the three phthalocyanine dyes as Q-switches for the ruby laser. Bleaching is substantial because of the large molar absorptivity in the ground state and the minimal excited-state absorption. As a check, we tested the indium compound in a configuration which we use routinely to produce mode locking of our ruby laser. If its short lifetime had involved substantial internal conversion direct to the ground state, we could have expected to observe reasonably efficient mode locking. In fact, we saw only poor mode locking along with good Q-switching. This is exactly as expected, given the actual dominance of the intersystem crossing decay channel, which produces a persistent bleaching due to a buildup of population in the metastable triplet state.

In summary, we have used a variety of modern laser techniques to characterize the photophysics of three group 3A phthalocyanines. The results, collected in Table I, confirm some existing lifetime data but correct luminescence yield values. New information on triplet yields is included. For the heaviest element, indium, there were no previous data at all. We may now add this group to the growing catalog of porphyrin analogues available to provide an extensive test for theories of nonradiative coupling and luminescence behavior. We confirm the applicability of the Strickler–Berg analysis and the usual heavy-atom effect on intersystem crossing. The series did not, however, prove useful for refining the Callis conjecture on internal conversion. His particular solutions and

measurements¹ remain unique in the extent of internal conversion reported. To detect trends in internal conversion in the porphyrin series, in general, it now appears, is going to require quantum-yield data with precision down to the 1% level.

Acknowledgments. This work was supported in part by the National Science Foundation, the Research Corporation, and the Academic Senate of the University of California. Computerized data acquisition was made possible by an NIH Research Resource.

References and Notes

- (1) J. B. Callis, Ph.D. Thesis, University of Washington, Seattle, Wash., 1970.
- (2) D. Magde, M. W. Windsor, D. Holton, and M. Gouterman, *Chem. Phys. Lett.*, **29**, 183 (1974).
- (3) S. P. McGlynn, T. Azumi, and M. Kinoshita, "Molecular Spectroscopy of the Triplet State", Prentice-Hall, Englewood Cliffs, N.J., 1969, Chapter 7.
- (4) D. Colaitis, *C. R. Acad. Sci.*, **242**, 1026 (1956).
- (5) H. E. Lessing, A. Von Jena, and M. Reichert, *Chem. Phys. Lett.*, **42**, 218 (1976).
- (6) J. H. Brannon and D. Magde, *J. Phys. Chem.*, **82**, 705 (1978).
- (7) D. Magde, J. H. Brannon, T. L. Cremers, and J. Olmsted III, *J. Phys. Chem.*, **83**, 696 (1979).
- (8) J. N. Demas and G. A. Crosby, *J. Phys. Chem.*, **75**, 991 (1971).
- (9) K. D. Mielenz, E. D. Ceheleik, and R. L. McKenzie, *J. Chem. Phys.*, **64**, 370 (1976).
- (10) S. J. Strickler and R. A. Berg, *J. Chem. Phys.*, **37**, 814 (1962).
- (11) D. Magde, *J. Chem. Phys.*, **68**, 3717 (1978).
- (12) J. N. Demas and G. A. Crosby, *J. Am. Chem. Soc.*, **93**, 2841 (1971).
- (13) T-H. Huang, K. E. Rieckhoff, E. M. Voigt, and E. R. Roland, *Chem. Phys.*, **19**, 25 (1977). This paper summarizes and references extensive earlier publications by this group.
- (14) D. Eastwood, L. Edwards, M. Gouterman, and J. Steinfeld, *J. Mol. Spectrosc.*, **20**, 381 (1966).
- (15) A. T. Gradyushko, A. N. Sevchenko, K. N. Solovyov, and M. P. Tsvirko, *Photochem. Photobiol.*, **11**, 387 (1970).
- (16) A. S. Pine, *J. Appl. Phys.*, **39**, 106 (1968).
- (17) G. P. Gurinovich and B. M. Jagorov in "Luminescence of Crystals, Molecules, and Solutions", Proceedings of the International Conference on Luminescence, Leningrad, Aug 1973, F. Williams, Ed., Plenum Press, New York, 1973, p. 196.
- (18) B. I. Stepanov, A. N. Rubinov, and V. A. Moslovnikov, *J. Appl. Spectrosc. (Engl. Transl.)*, **6**, 201 (1967).
- (19) J. B. Birks, "Photophysics of Aromatic Molecules", Wiley-Interscience, New York, 1970, Chapter 4.
- (20) M. Gouterman, F. P. Schwartz, P. D. Smith, and D. Dolphin, *J. Chem. Phys.*, **59**, 676 (1973).
- (21) G. W. Robinson and R. P. Frosch, *J. Chem. Phys.*, **37**, 1962 (1962).
- (22) G. W. Robinson and R. P. Frosch, *J. Chem. Phys.*, **38**, 1187 (1963).
- (23) J. P. Bryne, E. F. McCoy, and I. G. Ross, *Aust. J. Chem.*, **18**, 1589 (1965).
- (24) For a review see: G. W. Robinson in "Excited States", Vol 1, E. C. Lim, Ed., Academic Press, New York, 1974, Chapter 1.
- (25) Reference 19, Chapter 5.